

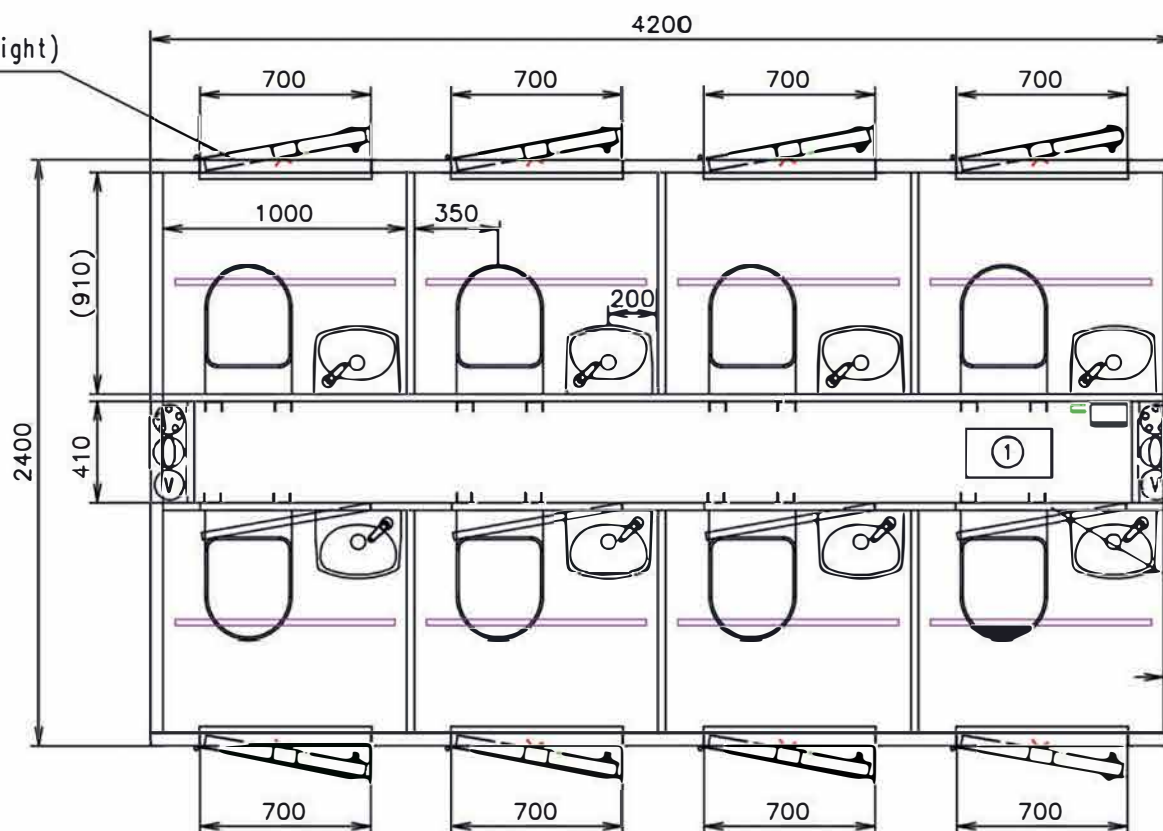

Connection hoses and cables	
Water hose:	✗
Waste water hose:	✗
Electric cable:	✗

Door to cabinets with sensor
+ LED RGB stripe over the door (red/green light)

Waste - outlet - Storz
Electricity and water - inlet



Stainless steel box
with water and electric connections
(on both sides)

Waste - inlet - Storz
Electricity and water - outlet

Technic door over toilet

50

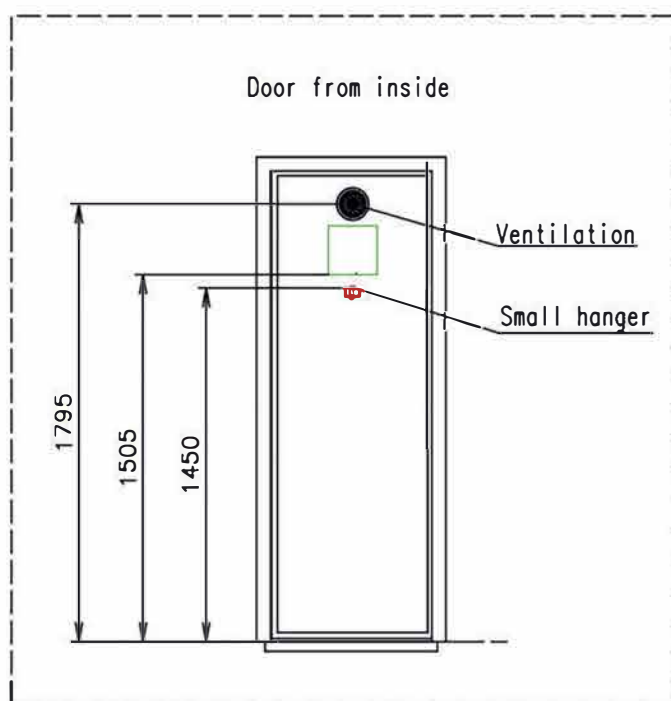

Door from inside

Ventilation

Small hanger

EWK frame - thickness 4mm

External door - automatic closing system

Door - simple handle from both sides + lock + "roller"
+ sensor + LED RGB stripe (green/red), without cylinder

Notes:

Interior height:	2200 mm	Total weight:	-
Color:	RAL 9010	Tare weight-estimate:	-
Floor:	PVC Supreme plus 030	Centre of wheels from rear side:	-
Date:	7.2.2023	Wheels:	-

SaniGreen

Drawing number:
4262-42-sketch 1 EWK_1/2 (Sprenger)

(Cabling and piping is not shown on the 3D views and drawings)



Connection hoses and cables	
Water hose:	✗
Waste water hose:	✗
Electric cable:	✗

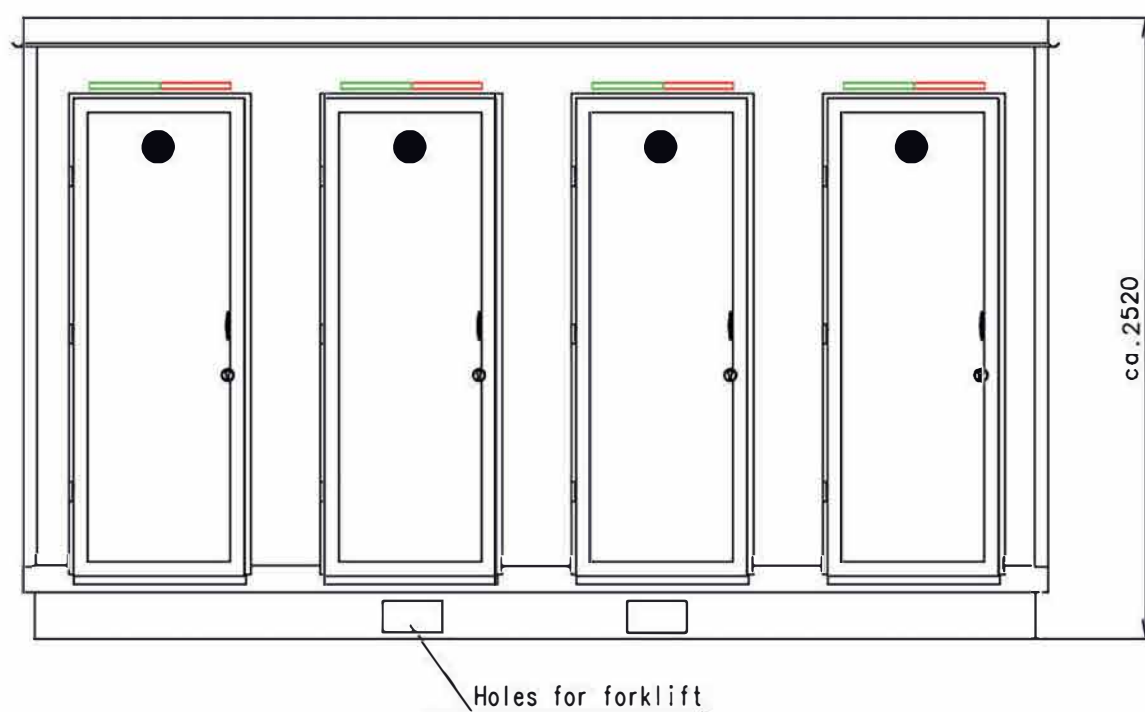
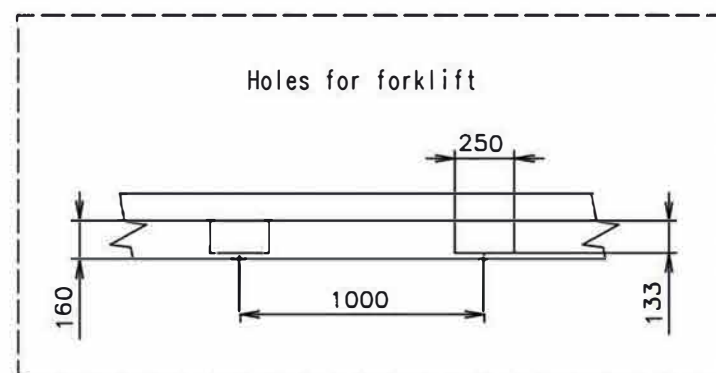
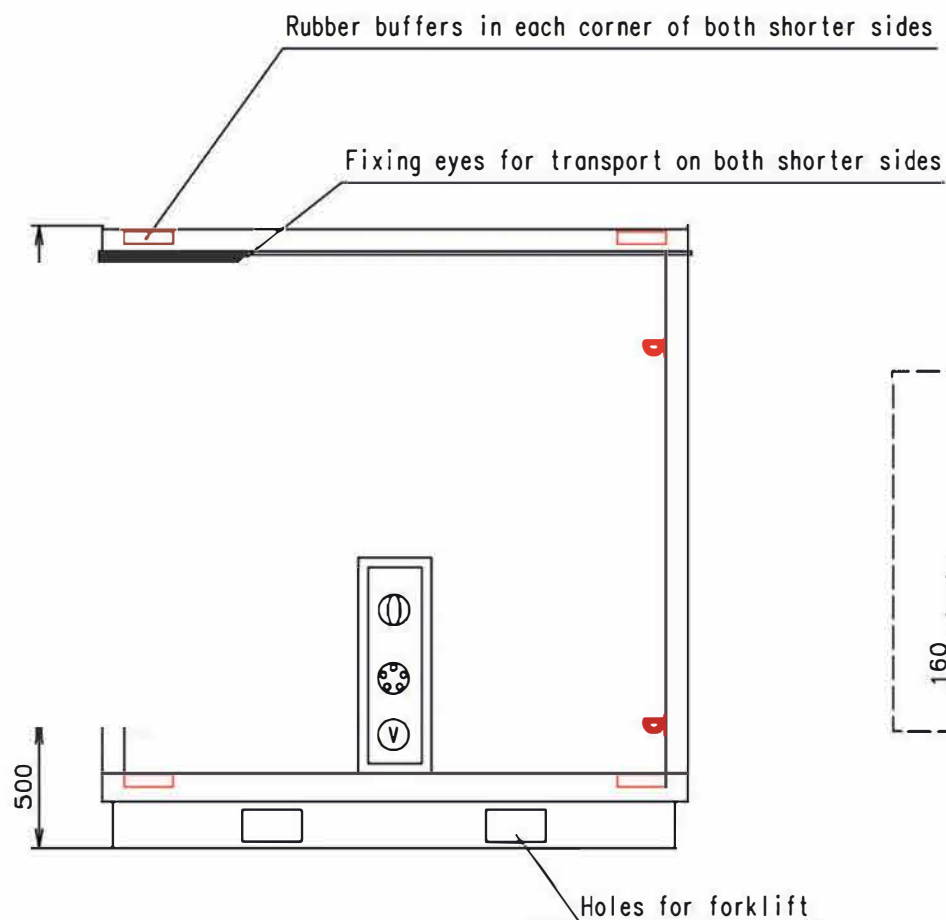

- Ⓥ Water connection 3/4" (through the wall)
- Ⓜ Electric connection (through the wall) (230V-16A)
- Ⓢ Effluent connection ø75 (through wall) Storz
- Light switch
- Ⓜ Switch board (1200 over floor)
- LED stripe
- Ⓜ Wash-basin Siko Multi (350x280) EUR913 + timing push water tap (only cold water)
- Ⓜ Vacuum toilet Jets
- Ⓜ Ventilation ø120
- Ⓜ Clothes hanger
- Mirror (200x200)
- ① Gray water tank Jets 12l

EWK frame - thickness 4mm

External door - automatic closing system

Door - simple handle from both sides + lock + "roller" + sensor + LED RGB stripe (green/red), without cylinder

Notes:

Interior height:	2200 mm	Total weight:	-
Color:	RAL 9010	Tare weight-estimate:	-
Floor:	PVC Supreme plus 030	Centre of wheels from rear side:	-
Date:	7.2.2023	Wheels:	-

Drawing number:

4262-42-sketch 1 EWK_2/2 (Sprenger)

(Cabling and piping is not shown on the 3D views and drawings)

SaniGreen