

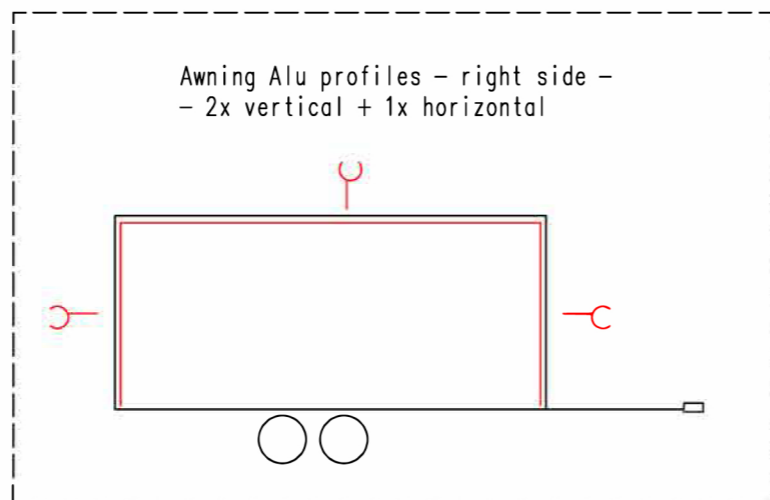

Connection hoses and cables	
Water hose:	✓
Waste water hose:	✓
Electric cable:	✓ 2x

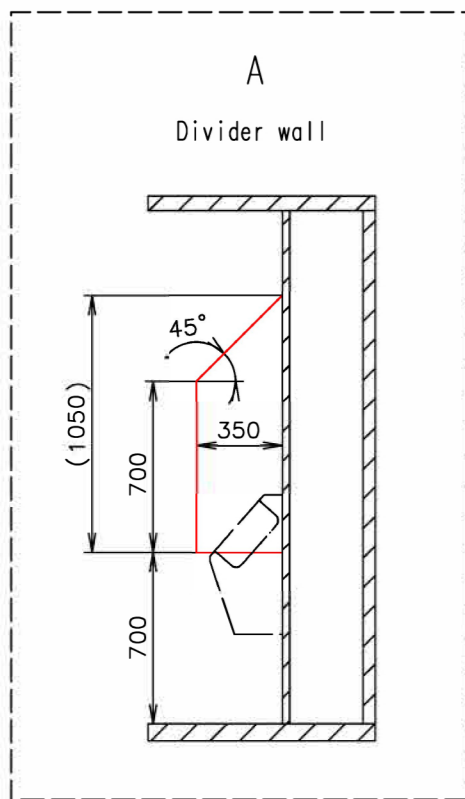
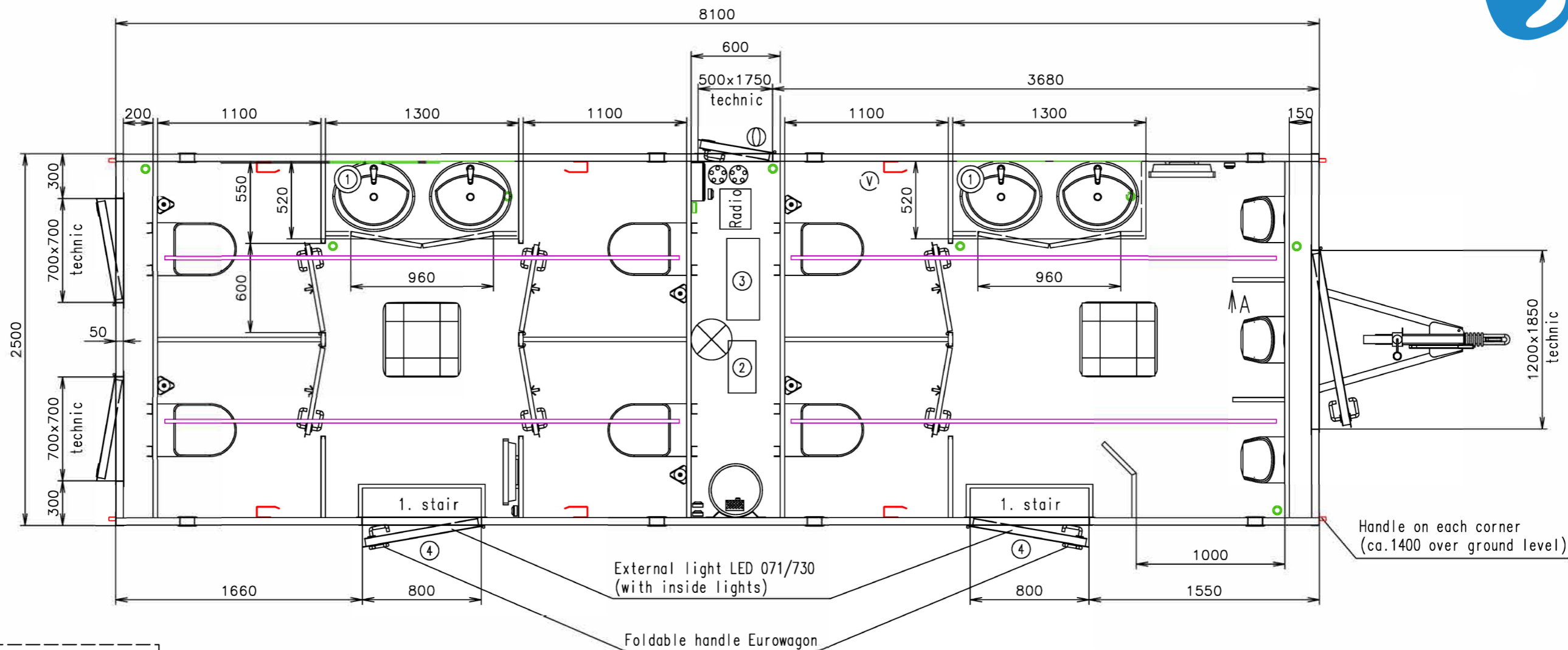

Working desks in waterproof compact desk Egger (dark color)

Interior doors and divider walls in decor 0599 SG Orca

Notes: External doors - without cylinders Spare wheel - free loaded

Interior height:	2100 mm	Total weight:	3000 kg
Color:	RAL 7042 (gray)	Tare weight-estimate:	2700 kg
Floor:	PVC Supreme plus 030	Centre of wheels from rear side:	4050 mm
Date:	24.9.2021	Wheels:	195/50 R13C

SaniGreen

Drawina number: (Sprenger)



Connection hoses and cables	
Water hose:	✓
Waste water hose:	✓
Electric cable:	✓ 2x

Ⓥ Water connection 3/4" (on the chassis) + filter + reduction valve

Ⓜ 2x Electric connection (through the wall) (230V-16A) (1x heatings) (1x the rest)

Ⓛ Effluent connection 1" (through wall)

Ⓜ Power point

Ⓜ Light switch

Ⓜ Switch board (1200 over floor)

Ⓜ Light LED stripe

⊗ LED sensorlight

Ⓜ Heating (200W)

Ⓜ Heating (750W)

Ⓜ Floor drain hole

Ⓜ Ventilation ø120

Ⓜ Wash-basin (built-in) Multi 1690 (550x470) + standard water tap

Ⓜ Vacuum toilet Jets (toilet seat – steel holders)

Ⓜ Urinal – Vitra Siko (water flush)

Ⓜ Hot water boiler Slim (30 l)

Ⓜ Roof window Dometic (400x400)

Ⓜ Brush toilet

Ⓜ Special toilet paper holder

Ⓜ Clothes hanger

Ⓜ Mirror (600x600) + black frame around

① Speaker

② Gray water tank Jets 12l

③ Vacuumator Jets 15MB

④ Foldable stairs Fiona (update on fixing of stair) + stainless steel handrail

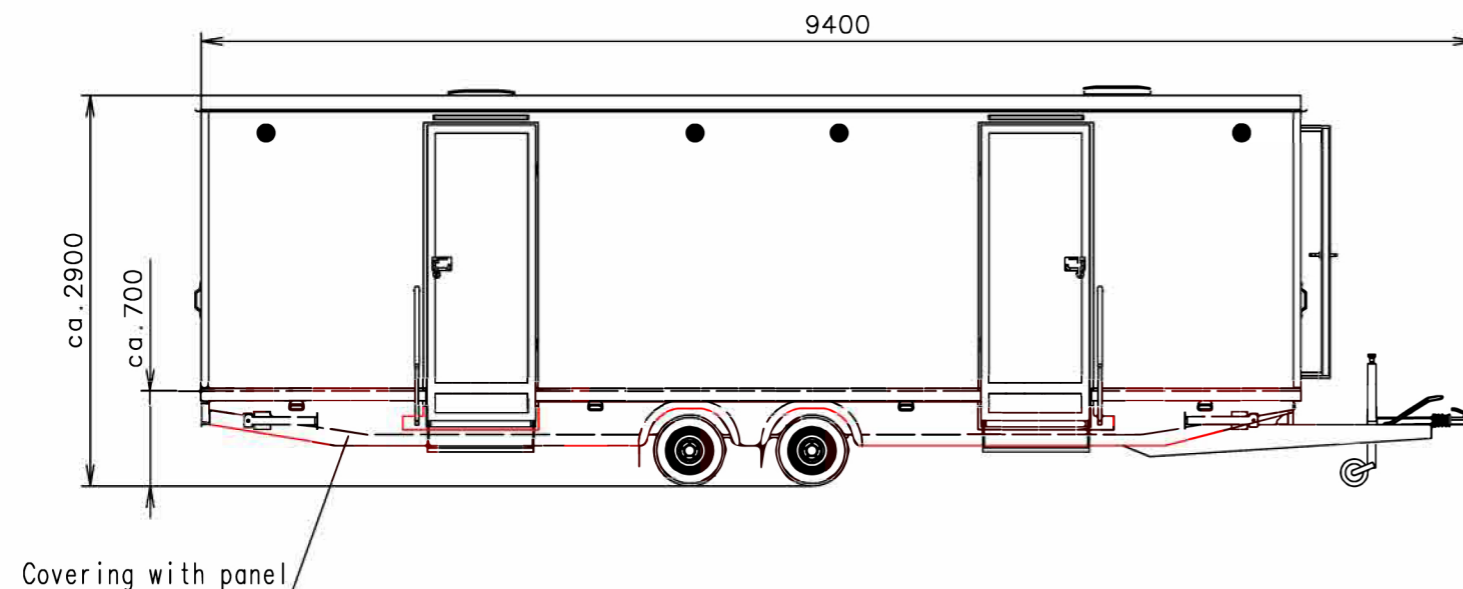

(Cabling and piping is not shown on the 3D views and drawings)

Working desks in waterproof compact desk Egger (dark color)

Interior doors and divider walls in decor 0599 SG Orca

Notes: External doors – without cylinders Spare wheel – free loaded

Interior height:	2100 mm	Total weight:	3000 kg
Color:	RAL 7042 (gray)	Tare weight-estimate:	2700 kg
Floor:	PVC Supreme plus 030	Centre of wheels from rear side:	4050 mm
Date:	24.9.2021	Wheels:	195/50 R13C

SaniGreen

Drawing number:

(Sprenger)