

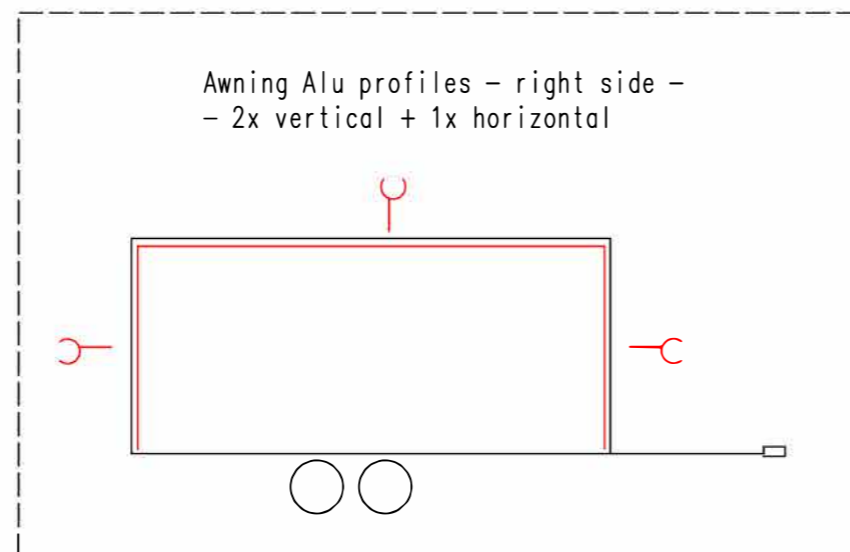

Connection hoses and cables	
Water hose:	✓
Waste water hose:	✗
Electric cable:	✓

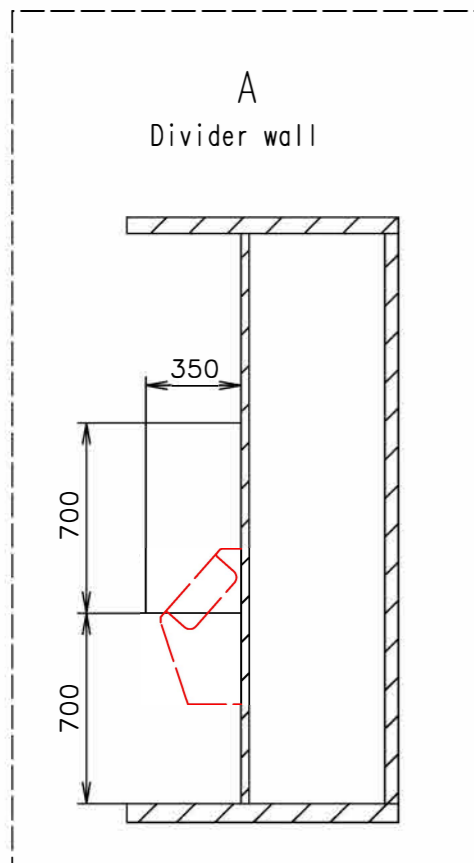
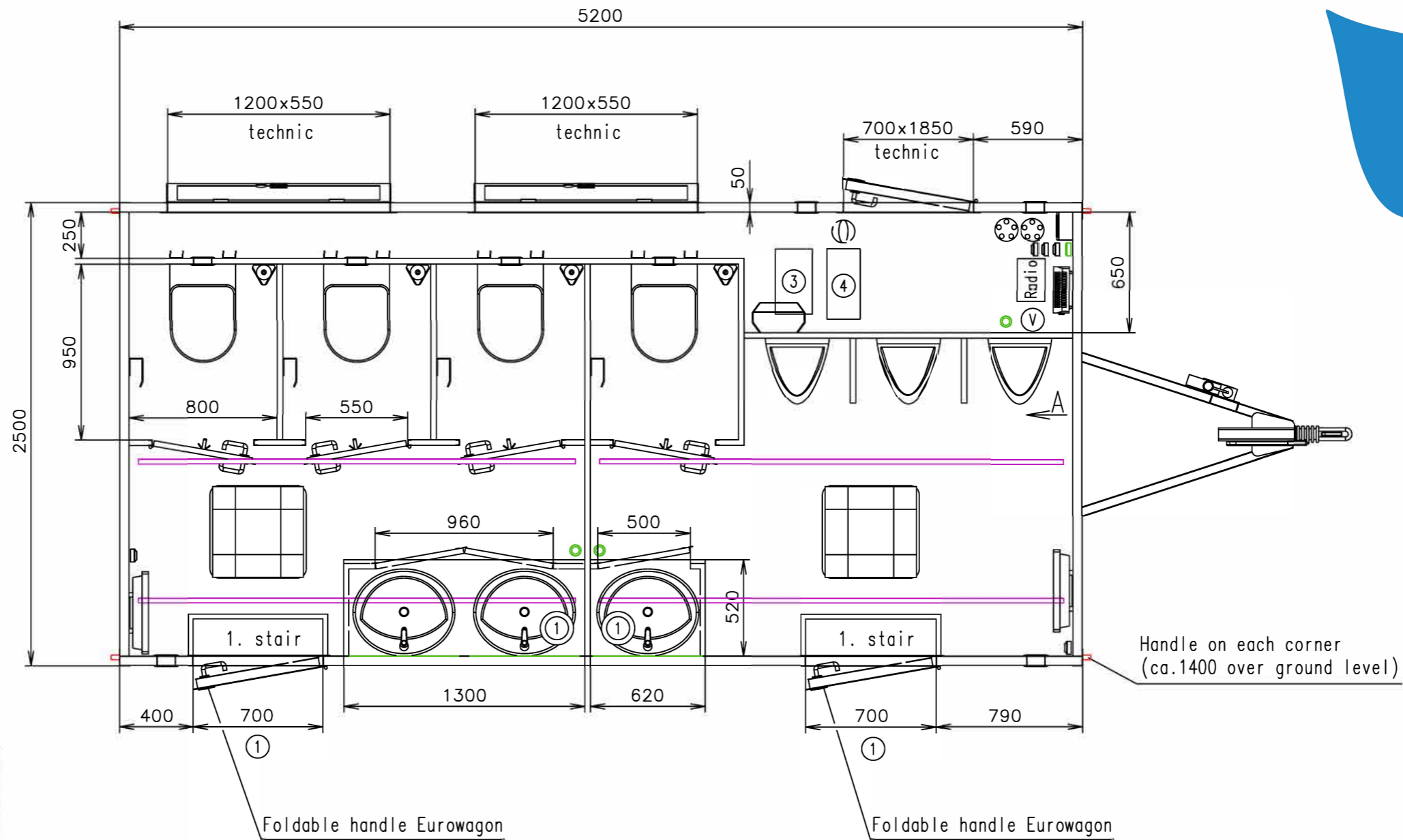

(Cabling and piping is not shown on the 3D views and drawings)

Working desks in waterproof compact desk Egger (dark color)

Interior doors + divider walls in black decor 6515

Notes: External doors - without cylinders Spare wheel - free loaded

Interior height:	2100 mm	Total weight:	2000 kg
Color:	RAL 7042 (gray)	Tare weight-estimate:	-
Floor:	PVC Supreme plus 030	Centre of wheels from rear side:	-
Date:	11.7.2022	Wheels:	155 R13

**SaniGreen**

Drawing number: (4109-37, WC3+1+3-52)  
4111-52-sketch 1\_1/2 (Sprenger)

Connection hoses and cables	
Water hose:	✓
Waste water hose:	✗
Electric cable:	✓ 2x



Ⓥ Water connection 3/4" (through the floor) + filter + reduction valve

⊗ 2x Electric connection (through the floor) (230V-16A) (1x heatings) (1x the rest)

Ⓢ Effluent connection 1"

⊖ Power point

⊖ Light switch

⊖ Switch board (1200 over floor)

— Light LED stripe

▬ Heating (500W)

▬ Heating (750W)

○ Floor drain hole

⊖ Wash-basin (built-in) Multi 1690 (550x470) + standard water tap

⊖ Vacuum toilet Jets

⊖ Urinal - Uridan (waterless)

⊖ Hot water boiler Wterm FHN (5l)

⊖ Roof window Dometic (400x400)

⊖ Ventilation ø120

⊖ Brush toilet

⊖ Toilet paper holder

↑ Clothes hanger

— Mirror (600x600) + black frame around

① Speaker - in the roof

③ Gray water tank Jets 12l

④ Vacuumator Jets 15MB

⑤ Foldable stairs Fiona (update on fixing of stair) + stainless steel handrail

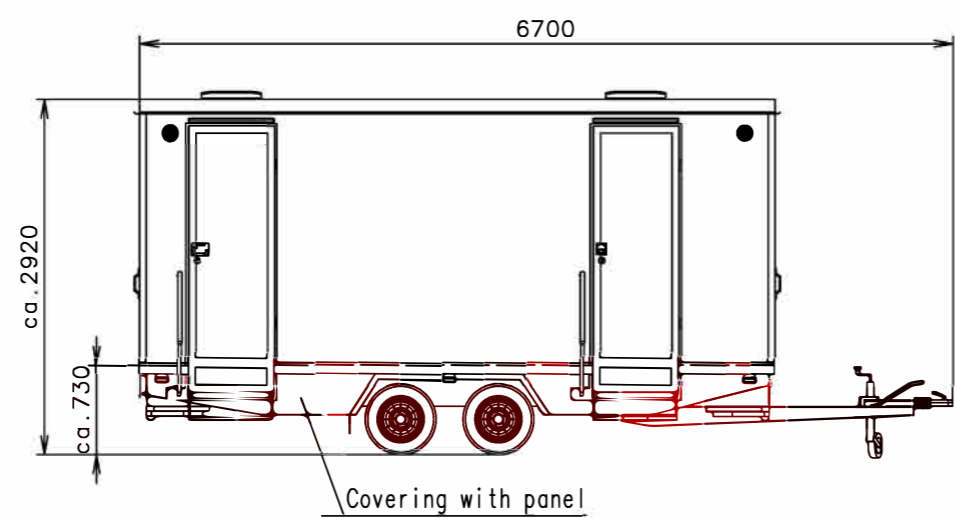

(Cabling and piping is not shown on the 3D views and drawings)

Working desks in waterproof compact desk Egger (dark color)

Interior doors + divider walls in black decor 6515

Notes: External doors - without cylinders | Spare wheel - free loaded

Interior height:	2100 mm	Total weight:	2000 kg
Color:	RAL 7042 (gray)	Tare weight-estimate:	-
Floor:	PVC Supreme plus 030	Centre of wheels from rear side:	-
Date:	11.7.2022	Wheels:	155 R13



Drawing number: (4109-37, WC3+1+3-52)  
4111-52-sketch 1\_2/2 (Sprenger)